

CONTRACT & APPLICATION FORM
THE TWENTY-THIRD ANNUAL
NANAIMO PROFESSIONAL CRAFT FAIR
Box 41 Lantzville, BC, VOR 2H0
250-390-3995 or 250-758-6494

Email: lindaknecht@shaw.ca ; colleliza@shaw.ca

Web Site www.nanaimoprofessionalcraftfair.com

I/We the undersigned herewith apply to participate in the **Nanaimo Professional Craft Fair, November 2,3 & 4 2012, at Beban Park Social Centre, 2300 Bowen Rd., Nanaimo, BC**, subject to acceptance by the jury of the Nanaimo Professional Craft Fair. On acceptance you will be notified what booth number has been assigned to you. A full refund will accompany any rejected application. **The jury will take place as required after the main jury that is done at the end of March each year.**

1. PAYMENT FOR SPACE-only registered Applicants paid in full may participate in the Nanaimo Professional Craft Fair. Payment of **\$50.00** must be included with this completed application to reserve a jury spot, the **balance to be paid by two postdated cheques dated June 1, 2012 & October 1, 2012 (included with application).** Applications received after October 1, 2012 must include full payment. In the event an application is not accepted by Nanaimo Professional Craft Fair for any reason, a full refund will be made (**\$15.00 fee will be charged for all N.S.F cheques**)

WITHDRAWAL OR CANCELLATION by Applicant prior to October 1, 2012 will be subject to a \$50.00 service charge; the remainder to be refunded. **After October 1, 2012, withdrawal will result in forfeiture of the entire amount paid** to Nanaimo Professional Craft Fair.

2. CHARACTER OF EXHIBIT-Nanaimo Professional Craft Fair reserves the right to decline or prohibit or restrict any exhibit, activity or conduct within the exhibit area which in its opinion is not suitable, such as raffles, sales of imported or manufactured goods or any other **non-craft pursuit.**

3. RENTAL CHARGES-Rental charges for booths are as follows: Single 8x10 booth, **\$325.00**; corner booth **\$375.00**; 8x14 booth **\$475.00** for three days, payable as per clause #1 above. All tax and license costs pertaining to booth rental, including temporary City of Nanaimo Business License and GST will be paid by Nanaimo Professional Craft Fair. The contracted space is for the sole and exclusive use of the Registered Exhibitor and **may not** be sub-leased. When two businesses are sharing a booth, each **must fill out & sign** an application form.

4. BOOTHS-Booths shall include 8 foot backdrop, most 8 x10 enclosure, **ONE** 8'x 30" table, chair(s), 2 lights and a power outlet. Corner booths may be open on 2 sides, if desired by removal of the end partition. An additional 6 ft table **may be available if reserved in advance.** **The charge for this additional table is \$20.00.**

5. INSTALLATION AND DISMANTLING-Exhibits shall be installed by the registered exhibitors between the hours of 8:00 a.m. and must be fully installed by 12:00 p.m. (noon) on Friday, November 2, 2012. No exhibit thus installed may be removed or dismantled prior to 4:00 p.m. November 4, 2012. Exhibits must be removed from the premises no later than 7:00 p.m. November 4, 2012.

6. EXHIBITION HOURS - Exhibitors shall staff their booths 12:00 p.m. till 8:00 p.m. November 2; 10:00 a.m. till 5:00 p.m. November 3; 10:00 a.m. till 4:00 p.m. November 4, 2012.

7. INSTRUCTIONS-The Exhibitor must closely observe the instructions issued by Nanaimo Professional Craft Fair whose decisions are binding.

8. DAMAGE TO FACILITIES-The Registered Exhibitor(s) will reimburse the Regional District of Nanaimo for any damage done to its property by the Registered Exhibitor(s) or by any employees or agents there of.

9. INDENMIFICATION-The Registered Exhibitor agrees to indemnify and save harmless Nanaimo Professional Craft Fair, Woodgrove Christian Community Church and the Regional District of Nanaimo from any and all liability arising out of the Exhibitor's participation in the Twenty-Third Annual Nanaimo Professional Craft Fair, including liability arising out of the Exhibitor's exhibit itself and the actions of the Exhibitors' employees and/or agents. It is recommended that the Exhibitor carry **suitable insurance** and all expenses of insurance shall be borne by the Exhibitor. In addition the afore mentioned parties shall not be liable in damages otherwise for failure to carry out the terms of the Agreement in whole or in part where caused directly or indirectly, by or in consequence of fire, storm, flood, war, rebellion, insurrection, riot, civil commotion, strike or by any cause whatever beyond the control of Management whether similar to or dissimilar from the causes enumerated herein. In any event, liability to the Registered Exhibitor for failure to carry out the terms of this agreement shall be limited to the return of the rental fee in whole or in part at the discretion of the Nanaimo Professional Craft Fair.

10. SECURITY & LIABILITY-Nanaimo Professional Craft Fair shall be responsible for the general security of the craft fair premises from 8:00 am November 2, 2012 until 7:00 pm November 4, 2012 but shall not be responsible for individual exhibits when the Exhibitor's booth is staffed and open to the public or not, and shall not in any event be responsible for care and control of the Exhibitor's equipment and property or the equipment and property of third parties used by the Exhibitor, all of which shall be the sole responsibility of the Exhibitor throughout the Nanaimo Professional Craft Fair.

NANAIMO PROFESSIONAL CRAFT FAIR FLOOR PLAN

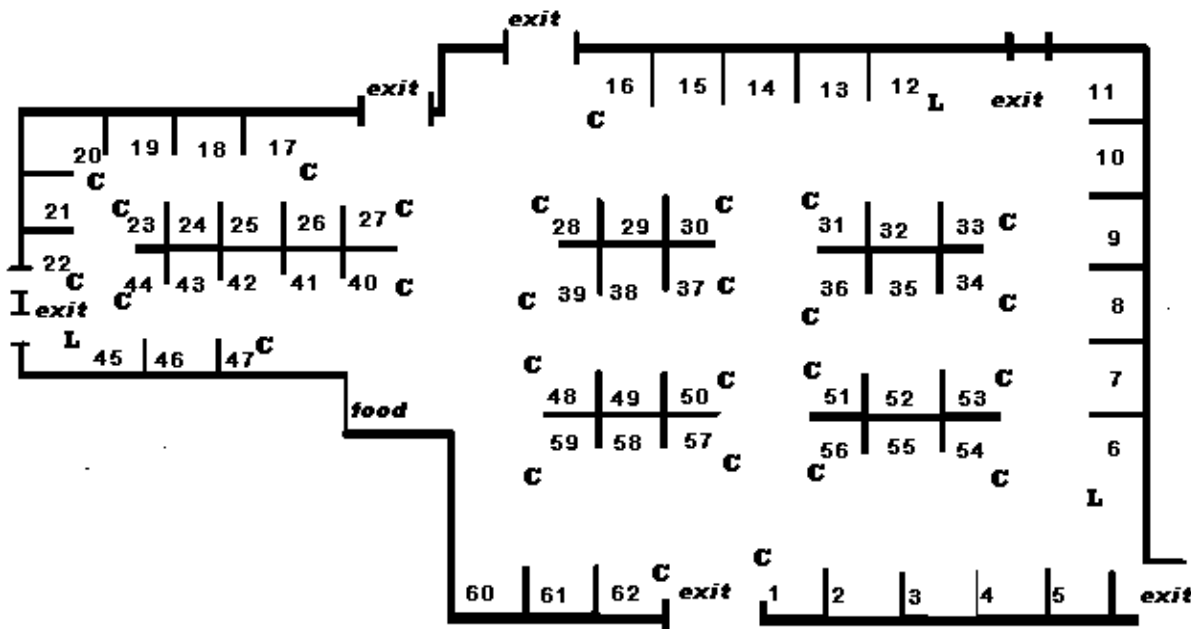

Corners booths Marked with "C" are \$375, Booths 12, 45, & 6 are \$475 & balance are \$325.

Co-ordinator:Linda Knecht 250-390-3995 or E-mail lindaknecht@shaw.ca

Assistant Co-ordinator: Colleen Shoquist 250-758-6494 or E-mail colleliza@shaw.ca

RETURN TO: NANAIMO PROFESSIONAL CRAFT FAIR, BOX 41, LANTZVILLE, BC, V0R 2H0

**CONTACT: Linda Knecht 250-390-3995 email lindaknecht@shaw.ca
OR Colleen Shoquist 250-758-6494 email colleliza@shaw.ca**

BUSINESS NAME: (Trade name) _____

CONTACT NAME: _____

ADDRESS: _____

CITY: _____ POSTAL CODE: _____

TELEPHONE: _____ EMAIL _____

Web Site: _____

BOOTH PREFERENCE: Corner Booth___ Regular Booth ___ Large Booth ___ Extra table _____
I HAVE READ THE 2012 CONTRACT FOR THE TWENTY-THIRD ANNUAL NANAIMO PROFESSIONAL CRAFT FAIR AND WILL ABIDE BY IT. **I WILL RELEASE THE NANAIMO PROFESSIONAL CRAFT FAIR AND WOODGROVE CHRISTIAN COMMUNITY CHURCH FROM ANY AND ALL LIABILITY FOR PERSONAL INJURY OR LOSS OR DAMAGE TO PERSONAL PROPERTY ARISING OUT OF MY PARTICIPATION IN THE NANAIMO PROFESSIONAL CRAFT FAIR OR USE OF VOLUNTEERS TO ASSIST IN MOVING.**

SIGNATURE: _____ DATED: _____

JURY RULES

NANAIMO PROFESSIONAL CRAFT FAIR JURY RULES PROHIBIT SALE OF IMPORTED, MANUFACTURED OR PURCHASED GOODS LACKING A MAJOR HAND-CRAFTED COMPONENT BY EXHIBITOR, RELATIVE OR FRIEND. TO MAKE IT A MORE ATTRACTIVE FAIR TO CUSTOMERS WE RESERVE THE RIGHT TO CHOOSE EXHIBITORS THAT MAY NOT FIT OUR JURIED DEFINITION OF A CRAFT. (food, digital art etc)

Describe your Craft, especially what **YOU** do that makes it a Craft. Please **include** photos (good close-ups) that include you. Digital pictures sent to lindaknecht@shaw.ca are preferred. Regular photos will be returned the first day of the Fair.

(Use Back of this page if not enough room or include write up.)

Permission to give **YOUR PHONE NUMBER** to customers who often call after the Fair is over. Yes__ No_
Will you be **needing a table** in your booth Yes__ No__ (**One table** per booth supplied) extra table Yes__ No_
Will you **donate a prize** for the hourly draws (once during the Fair) Yes__ No_
(Winners will be brought to your booth to pick up their prize)
May we use a **photo** (one supplied by you or taken previously) for possible publicity purposes? Yes__ No_
May we give your name address and pictures to the media for advertising purposes? Yes__ No_